

KEY INSTALLATION CONSIDERATIONS

- Karastan LuxeCraft flooring is intended for interior use only and is suitable for applications above, on, and below grade. DO NOT install in any outside area, saunas, seasonal porches, camping trailers, boats, RVs, lanais, rooms that are prone to flooding, or rooms or homes that are not temperature controlled.
- LuxeCraft is a floating floor and should be allowed to expand and contract freely. It must not be glued, nailed, or fastened to the subfloor in any way. Permanent cabinets, vanities, islands and similar items should be installed first. Then, install LuxeCraft flooring around them, leaving the proper expansion gap. LuxeCraft can be installed under vanities with legs. LuxeCraft can be installed under toilets. Leave proper expansion space around the flange and use a premium waterproof 100% silicone caulk. Do not anchor toilet through the material.
- LuxeCraft is a waterproof floating floor, but it should not be used to seal an existing floor from moisture. It cannot inhibit the growth of mold or prevent structural problems associated with or caused by flooding, excessive moisture, alkalis in the subfloor, or conditions arising from hydrostatic pressure. Regardless of location, always remove standing water, urine and other liquids promptly. Job site moisture issues should be addressed and corrected prior to installation. Fill expansion spaces around potential wet areas only with premium waterproof 100% caulk.
- Long-term exposure to direct sunlight can potentially damage LuxeCraft flooring, causing it to discolor, fade or buckle. Protect your flooring from exposure to direct sunlight via the use of window treatments or UV-tinting on windows.
- If the flooring is to be installed by a third party, then it is suggested that the homeowner be present during the installation for consultation and/or direction. The owner and installer should discuss installation and layout to maximize satisfaction. If this is not possible, consultation should occur prior to the installation. The owner/installer assumes all responsibility for quality of completed installation.

BEFORE STARTING

Before beginning a LuxeCraft flooring installation project, it is critical that you 1) fully acquaint yourself with the detailer installation instructions for your specific flooring and subfloor type, and 2) conduct a complete job site evaluation.

- Always check Karastan.com for the latest installation instructions and warranty information. It is the responsibility of the installer to ensure that the most current documents are followed during installation.
- Make a complete job site evaluation to assure that environmental conditions are acceptable for LuxeCraft flooring. Conditions between 55°F and 85°F (13°C and 30°C) are required before and during installation. For more detail, please reference the “Installation Prep” section of this guide.
- Determine the quantity of LuxeCraft flooring, flooring transitions and wall trim needed for your installation. It is recommended that you add an additional 10% to your square footage for standard installations to account for cuts. For diagonal installations, add 15%.
- Make sure you have the appropriate installation tools. A list of recommended installation tools can be found in the “Tools Required for Installation” section of this guide.
- Cartons should be evenly stacked no more than five cartons high on a flat surface and away from heating or cooling ducts or direct sunlight.

TOOLS REQUIRED FOR INSTALLATION

- Tape Measure
- Utility Knife
- Eye Protection
- Gloves
- Tapping Block
- Soft Faced Hammer
- Pull Bar
- 1/4” Spacers
- Level

OPTIONAL TOOLS:

- Reciprocating Saw
- Miter or Circular Saw
- Carpenter’s Square

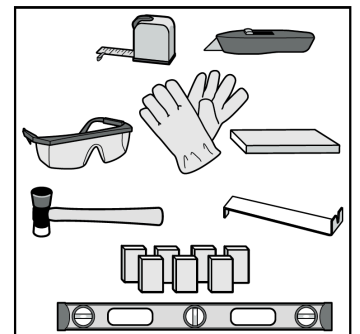

SITE PREPARATIONS

Prior to installation, the homeowner or installer must ensure that job site conditions (including subfloor or substrate, ambient temperature and relative humidity) will not negatively affect the floor. The manufacturer is not responsible for damages associated with improper installation or poor site conditions.

- A. The surface subfloor must be flat. The flatness requirement is defined as follows: the maximum difference between two high points and the intermediate low point is 1/4" in a 10' radius. Surface flatness must not vary more than 1/16" when measured with a 3' straight edge. Additionally, the subfloor must not slope more than 1" in 6'. LuxeCraft flooring must be adhered on ramps.
- B. High areas can be sanded, ground down or floated over with an approved self-leveling compound. Fill excessive voids or low areas using a non-gypsum, cementitious based leveling compound. Allow the leveling compound to dry thoroughly before beginning the LuxeCraft floor installation. Follow the manufacturer's instructions to ensure leveling compound is appropriate for the application.
- C. Subfloors must be structurally sound without deflection. Cartons should be evenly stacked no more than five cartons high on a flat surface and way from any heating or cooling ducts or direct sunlight.
- D. Crawl Spaces: Concrete slab or ground must be dry. Ensure that crawl spaces have open vents year-round to ensure proper air circulation and prevent moisture build-up. The ground in the crawl spaces must be completely covered using 6 mil polyethylene. Crawl space clearance between the earth and underside of joists should be no less than 18" (45.7 com), and the perimeter vent area should be equal to 1.5% of the total square footage of the crawl space or as mandated by code.
- E. Carefully remove any existing quarter round or base board molding.
- F. Always remove carpet, carpet pad and tack strips.
- G. Remove any existing floating or un-adhered flooring.
- H. Be sure the surface of the subfloor is flat, clean, dry and sound before starting.
- I. Inspect every plank for any shipping damage when removing from the carton.
- J. Kitchen cabinets must be installed before the floor is installed. Do not install cabinets on top of Karastan LuxeCraft flooring.

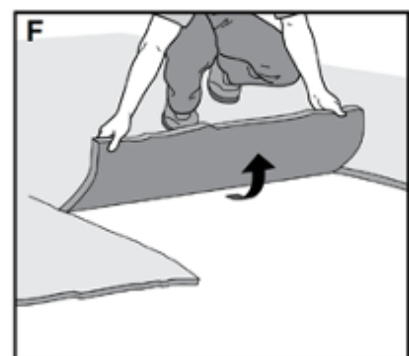
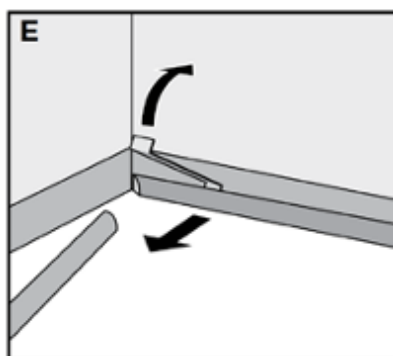
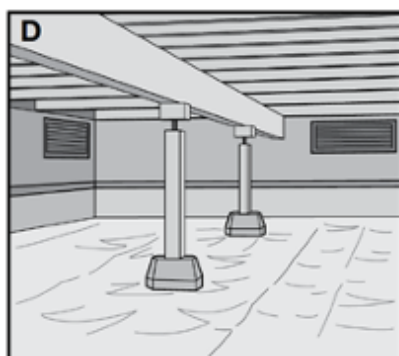
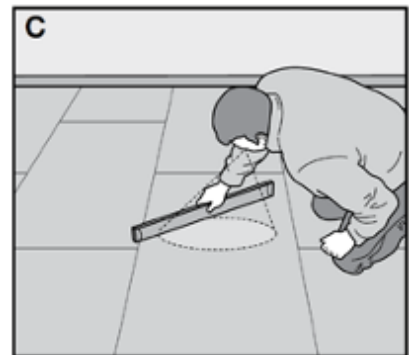
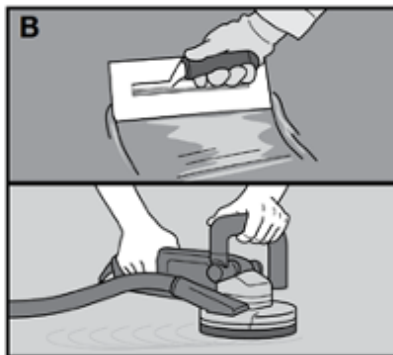
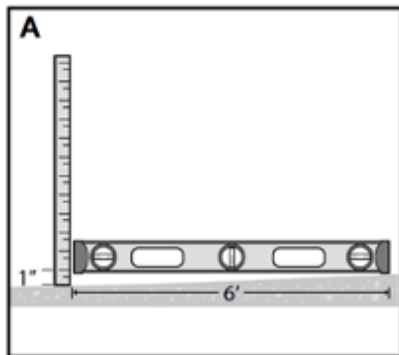

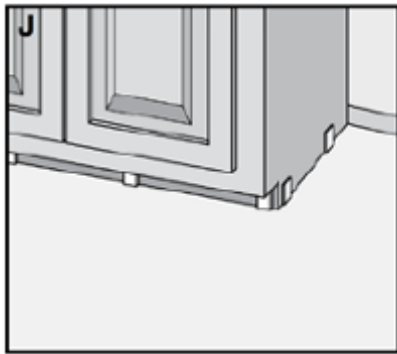
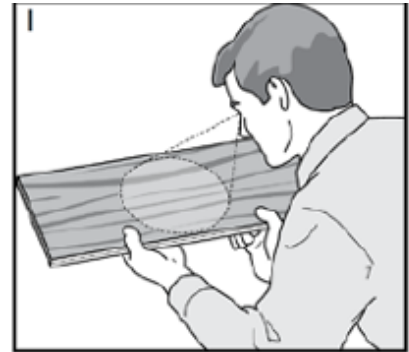
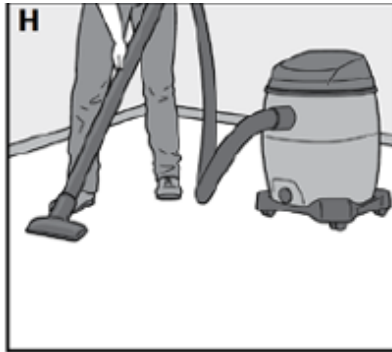
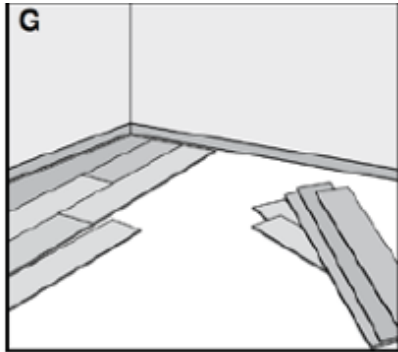

APPROVED SUBFLOORS

Concrete, plywood, OSB, particleboard, chipboard, hardwood (solid, engineered, parquet), tile (ceramic, terrazzo, stone, asbestos, peel and stick). Non-cushion sheet vinyl, metal, VCT, and DRIcore are acceptable substrates. All subfloor requirements noted below must be met prior to the installation of Karastan LuxeCraft flooring.

CONCRETE SUBFLOOR PREP

- Perform moisture tests at locations around exterior doorways, near walls containing plumbing, near foundation walls and in the center of the room.
- High spots can be removed by grinding. Depressions can be filled with patching compound formulated for use in floor installation.
- Newly laid concrete slabs must cure for at least 90 days prior to installation.
- Concrete can be either sealed or unsealed.
- Moisture levels of concrete slabs before, during and after installation must be < or = to 8 lbs./1000ft 24-hr using an anhydrous calcium chloride test according to ASTM F1869, and pH must be between 5.0 and 9.0; or, if using ASTM F2170 in-situ probes, relative humidity should be less than 90%. Always measure, record, and retain your test results.

WOOD SUBFLOORS (Plywood, OSB, Particleboard, Chipboard, Solid Hardwood or Luan)

- Wood subfloors must be APA approved with a minimum grad of BB or CC. (For reference, APA refers to American Plywood Association, now known as the Engineered Wood Association).
- Perform moisture tests using a reliable moisture meter in multiple locations. Moisture readings should never exceed 14% for plywood, OSB, particleboard, chipboard, or solid hardwood subfloors. If moisture readings exceed 14%, conditions must be corrected at the job site before installation of LuxeCraft flooring.



Installation Instructions

OTHER SUBFLOOR PREP

- Adhered and sound vinyl sheet good, vinyl tiles, linoleum and resilient (VCT) tiles usually do not need to be removed if they are fully bonded and free from notable damage. Some old vinyl sheet goods and tile contain asbestos. Should existing flooring contain asbestos, special precautions must be taken for your safety. Contact a professional immediately for inspection and removal.
- Ceramic tiles and terrazzo usually do not need to be removed. Grout joints wider than 1/4" must be filled. LuxeCraft flooring may be installed directly over ceramic tiles and terrazzo, provided they are fully adhered, smooth, sound and dry. These flooring materials must be smooth and flat to within 1/4" in a 10' radius and must not vary more than 1/16" when measured with a 3' straight edge.
- Do not install over more than one layer of existing vinyl.

RADIANT FLOORING HEATING PREP

- After market radiant heated floors must be approved by the manufacturer for use with resilient flooring applications.
- The subfloor temperature should not exceed 85°F (29°C).

LIST OF APPROVED SUBFLOORS

Carpeting/Carpet Pad	Cork
Cushioned Vinyl Flooring	Engineered Hardwood Over Concrete
Flooring Floors	Sleeper Substrates
Laminate	Hardwood Over Concrete
Parquet Over Concrete	Rubber

LUXECRAFT INSTALLATION INSTRUCTIONS

- LuxeCraft flooring is intended for indoor use only.
- Extreme ranges between 0°F to 50°F (-18°C to 10°C) and 100°F to 140°F (37°C to 60°C) apply to unoccupied environments only. Occupied areas need to be controlled between 50°F to 100°F (10°C to 37°C).
- A 1/4" (6 mm) expansion space must be maintained around the perimeter of the room and any fixed objects such as pipes and columns.
- Use approved safety equipment to provide proper protection based on each given task.
- Door jambs and casings must be undercut so that the plank can slide underneath. A 1/4" (6 mm) expansion space must be included around the undercut jambs and casings. A reciprocating saw is recommended to create the necessary undercut. Never undercut metal door casings. Cutting Tip: To undercut the casting, lay a scrap piece of flooring next to the casting and lay the saw flat on the top of the flooring so that the saw easily cuts to the height of the plank.
- Important: Always inspect each plank to ensure it is not damaged prior to installation. Check the tongue and groove to ensure both are free of debris or damage.
- It is recommended to blend flooring from multiple cartons during installation.
- Cartons should be evenly stacked no more than five cartons high on a flat surface and away from any heating or cooling ducts or direct sunlight.
- Excess flooring should be stored in a protected and climate-controlled environment for possible future repairs.
- The room temperature must be maintained between 55°F and 85°F for 48 hours before, during and 48 hours after installation.
- Power tools can be dangerous. Operate in strict accordance with manufacturer's operating instructions and safety precautions. Unsafe and improper use can cause serious injuries. Avoid inhalation and exposure to airborne particles by wearing personal protective equipment, including NIOSH or OSHA approved dust masks, safety goggles, and work gloves.

LUXECRAFT UNICLIC LOCK INSTALLATION INSTRUCTIONS

1. Inspect each plank. Blend planks from several cartons at the same time to ensure good color and shade mixture throughout the installation.
2. It is recommended that installation begin in a corner of the room. Between the first row of flooring and the wall, inspect spacers so that 1/4" (6 mm) gap is maintained.
3. When installing the first row, gently insert the short edge of one plank into the short edge of another plank at slight angle and rotate downward. With the newly installed plank lying flat, use your hand to press down on the newly formed joint. The end joint should click flush with the previous plank. Continue to complete the starter row, maintaining a straight edge for the following row.

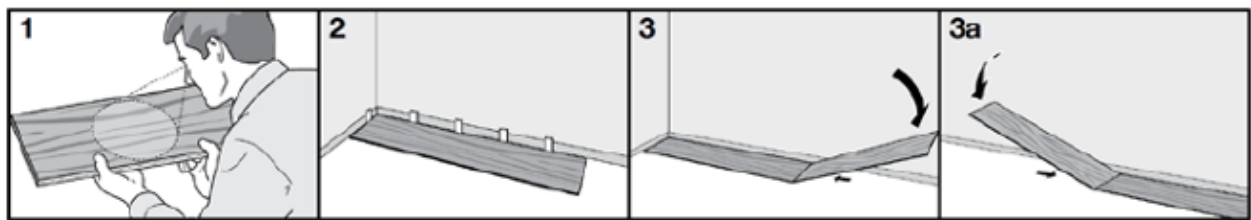

4. Use a tapping block and soft faced hammer to close any gaps between the planks.
5. Once you reach the end of the first row, measure and cut the final plank so that it completes the row while also leaving a necessary 1/4" expansion gap. Last planks of rows must be at least 8" long. Note: Use a spare plank to create a straight edge at the cut line. Use a utility knife to score the top of the pattern and snap the panel. It will be necessary to cut the foam underlayment after snapping the panel.
6. Start the second row of flooring by using the trimmed planks from the previous row. First pieces must be at least 8" long. End joints should be staggered a minimum of 6" from one row to the next.

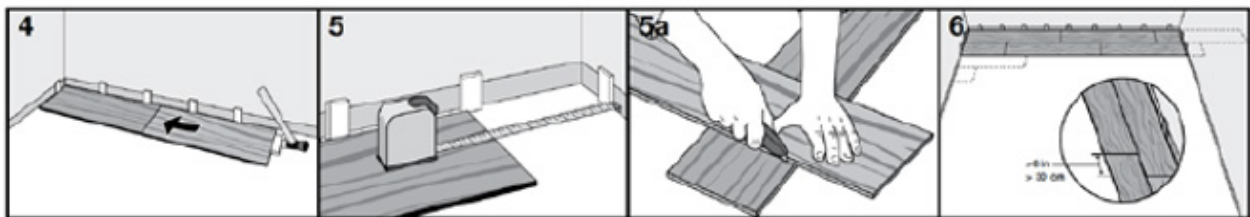

7. At a slight angle, insert the long edge tongue of the first plank in row 2 into the long edge groove of the plank in row 1 until the plank edges meet, and then rotate down until the joints lock.
8. When joining the next plank in the second row, join the long side edge first to the plank in row 1. Slide the plank sideways and rotate the plank down so that the end of the new plank gently meets the end of the first plank in row 2. Using your hand press down on the newly formed joint. The end joint should click flush with the previous plank.
9. Repeat these steps to complete the installation
10. After each row is complete, ensure there will be a 1/4" (6 mm) gap to the wall, after the joints are closed, for expansion.

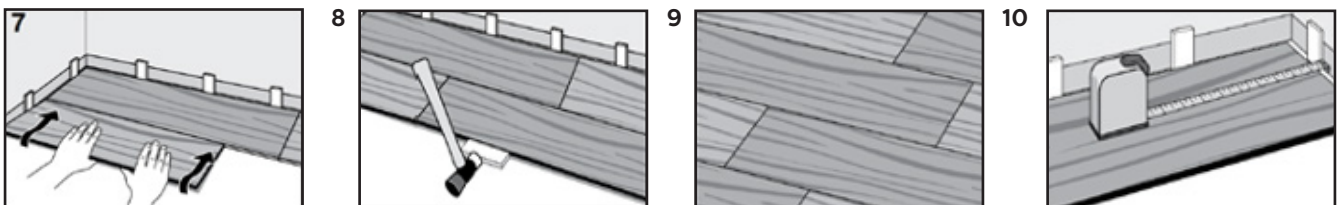

11. For the last row, align the plank to be used on top of the 2nd to last row. Using a full width plank as a spacer, trace the wall contour. Use a full plank as a straight edge to cut the plank. Insert the long edge tongue into the long edge groove and use a pull bar and hammer to close the gap.



12. When the new flooring meets a threshold or a doorway, we recommend undercutting the door jamb. To secure the right cut, turn a plank upside down and place it on the floor up to the door frame. Then place a reciprocating saw flat against the plank and simply cut through the frame. Remove the cut-out piece and vacuum away debris. Slide plank under pre-cut door frame. Door frame should be cut so that a 1/4" (6 mm) gap is located from the edge of the plank under the casing to the wall.

13. Tap the long side joint closed first, then tap the end joint closed.

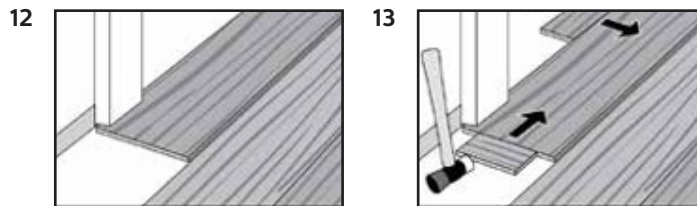

14. Allow 1/4" (6 mm) expansion space around pipes or other fixed objects.

15. In rows where there is a pipe, make sure that the pipe falls exactly in line with the short side of two planks. Select a drill bit with the same diameter as the pipe plus 1/4" (13 mm). Click the planks together on the short side and drill a hole centered on the joint between the two planks. Then install the planks.

16. For a double pipe, drill a hole equivalent to the diameter of the pipe plus 1/4" (13 mm) at each of the marked points. If located on the long side of the plank, make a 45° cut from each hole to the edge of the plank. Then, using an appropriate glue along the cut edges of the piece you cut out, glue the piece in place. Be sure no glue comes between the cut-out piece and the subfloor.

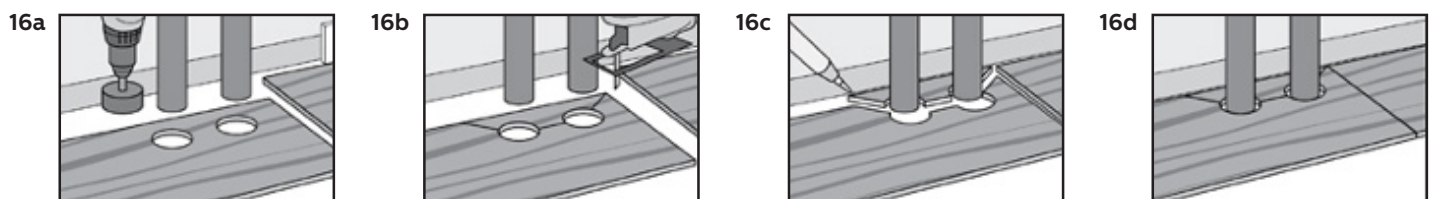
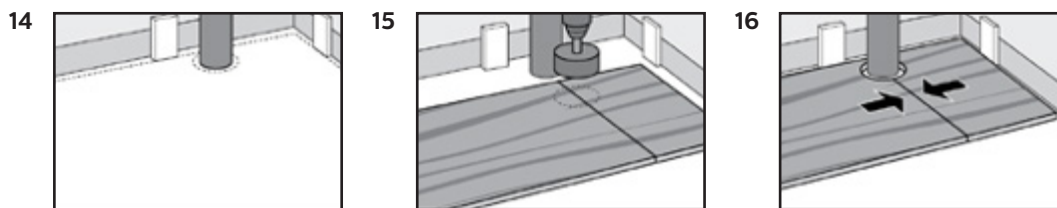

17. Remove all spacers.
18. Fill any expansion spaces around potentially wet areas, such as refrigerators, tubs, etc., with premium waterproof 100% silicone caulk.
19. When installing LuxeCraft in any room or area larger than 100 lineal feet (30.5 m) in any direction, the use of coordinating RevoFit™ is required to separate the floor into sections no larger than 100' x 100' (30.5 m x 30.5 m) per section.
20. Install moldings to cover the expansion gap. When installing moldings never allow nails or screws to enter the LuxeCraft flooring or the expansion zone around the flooring perimeter. All moldings and transition strips need to provide a 1/4" (6 mm) expansion space as well.

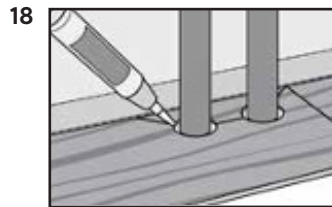
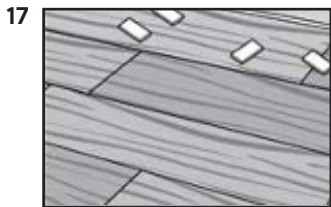

CARE & CLEANING

PREVENTATIVE MAINTENANCE

Prevent indentations and scratches by using non-staining floor protectors on the legs of chairs, appliances and all heavy furniture. Floor protectors should be at least 1" in diameter. Periodically clean protectors to remove grit that may become embedded and cause scratching.

Replace plastic or metal chair casters with rubber and keep casters clean.

Place walk-off mat at entrances. Mats should have a non-rubberized backing and be labeled as non-staining.

We recommend the use of a hard surface (non-studded), non-rubber chair mat to protect your floor from office chairs with casters. Light, rolling furniture should be outfitted with broad-surface, non-staining casters that have been engineered for hard surface floors. Such casters should be a minimum of 1" (2.5 cm) wide and at least 2" (5.1 cm) in diameter.

Keep pets' nails trimmed.

Remove shoes with cleats, spikes or pointed high heels before walking on the floor.

CLEANING

Sweep the floor regularly with a soft bristle broom to remove loose dirt.

Wash the floor with non-abrasive, neutral PH floor cleaner approved for vinyl floors.

For everyday cleaning, a mop moistened with warm water will suffice.

NOT RECOMMENDED FOR CLEANING

Detergent based cleaners

Abrasive or mop and shine products

Ammonia or bleaches

Vacuum cleaner with rotating beater bar engaged

Note: Always read the cautionary information on all cleaners prior to use.

Important: Never push, pull or drag furniture, appliances or other items across the floor. Always lift and carry furniture and heavy items.

For technical assistance, please contact your flooring dealer or Technical Services at 888.387.9881, option 3.